

Specifications

All models	
Supply Voltage	230-240V a.c.
Power Factor	> 0.9
Colour Temperature	4000K
IP Rating	IP65

Installation:

- Disconnect mains supply before installing, servicing or maintaining the luminaire.
- Attach the stainless steel clips to the body of the luminaire and attach the row of clips on one side of the luminaire to the diffuser (clip must be attached to the protruding side of the diffuser).
- The gear tray should be detached to assist with installation by twisting the quarter turn fasteners.
- Drill out mounting holes as shown in the specification table.
- Use the supplied screw set to ensure IP65 is maintained.
- Fit the power cable through the supplied IP65 gland.
- Make the electrical connection at the terminal block:
 - N – Neutral
 - A – Active
 - E – Earth
- For DALI models connect the data cable to the two terminals labelled "DA".
- For Emergency models, an additional Switched Active terminal is provided to allow the luminaire to be switched on and off in mains mode. For non-maintained operation, do not connect the switched active terminal.
- Clip and secure the lanyards to the gear tray.
- Secure the gear tray to the base.
- Close the diffuser and ensure diffuser clips are locked in place.

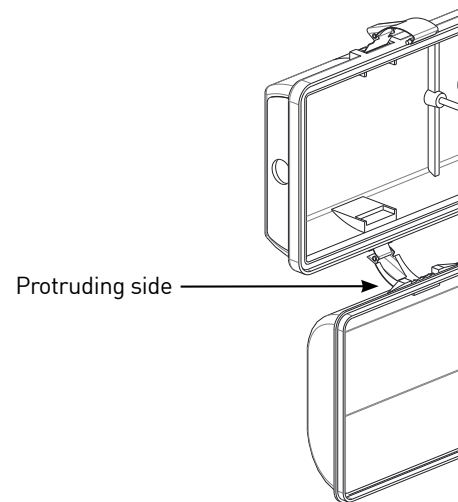

Installation positions and IP rating

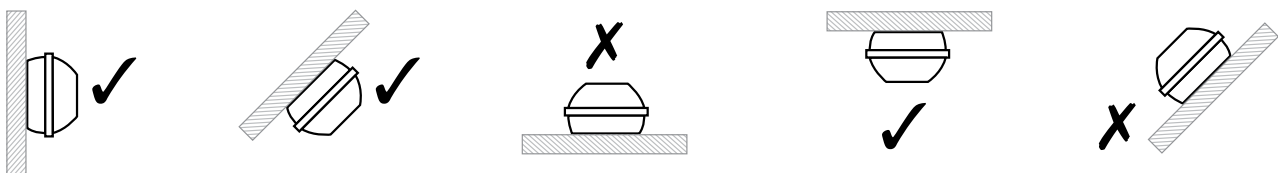

Movement sensor (selected models only)

These models contain a microwave - type movement sensor, configured to operate in one of the following ways:

On/off models	These units turn on when movement is detected and turn off after a certain time period has elapsed with no movement.
Auto occupancy models	These units turn on when movement is detected and dim down to 10% brightness after a certain time period has elapsed with no movement.

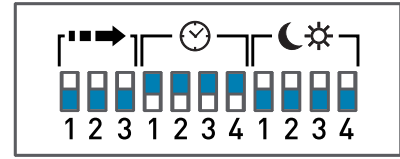

For all of these models, the user can change the following settings:

Key: ● = Switch up ○ = Switch down

1. Detection area

Detection area can be reduced by selecting the combination on the DIP switches to fit precisely for each specific application.

	1	2	3	
I	●	●	●	100%
II	●	○	●	75%
III	○	○	●	50%
IV	○	●	○	25%
V	●	○	○	10%

Detection Area Hold Time Daylight Sensor

- I - Detection range 100%
- II - Detection range 75%
- III - Detection range 50%
- IV - Detection range 25%
- V - Detection range 10%

2. Hold Time

Hold-time means the time period you would like to keep the lamp on 100% after the person has left the detection area.

	1	2	3	4	
I	●	●	●	●	30min
II	○	○	○	●	20min
III	○	○	●	○	6min
IV	○	●	○	○	90s
V	●	○	○	○	30s
VI	○	○	○	○	10s

- I - 30 minutes
- II - 20 minutes
- III - 6 minutes
- IV - 90s
- V - 30s
- VI - 10s

3. Daylight Sensor

The daylight threshold can be set on DIP switches, to fit a particular application.

	1	2	3	4	
I	●	●	●	●	Disable
II	○	○	●	○	50Lux
III	○	●	○	○	30Lux
IV	●	○	○	○	10Lux
V	○	○	○	○	5Lux

- I - Photocell disabled
- II - 50 lux daylight operation
- III - 30 lux daylight operation
- IV - 10 lux twilight operation
- V - 5 lux darkness operation only

For example, when set to 50 Lux, the movement sensor will only operate when the ambient light level is below 50 lux. When set to Disable, the movement sensor will operate all the time.

→ Indicates default settings.

Disclaimer:

1. This product must be installed and used as per these instructions.
2. This product must be installed by a licenced electrician.
3. Famco reserves the right to modify the specifications of this product at any time.
4. This product should only be cleaned with a damp cloth. Cleaning agents and solvents should not be used.
5. The IP rating of this product is only valid when all applicable seals, glands and their appropriate cables are installed correctly.
6. This product has no user serviceable parts and no attempt should be made to repair this product. For repair please contact Famco.
7. Extended exposure to UV rays (such as exposure to direct sunlight) may cause discolouration of this product.
8. Severe electromagnetic interference from other products may cause malfunction of this product.
9. This product is not suitable for marine environments such as areas subject to salt spray and/or mist.
10. This product is not suitable for installation in hazardous and/or corrosive areas.
11. The material in this product may vary in colour from batch to batch. Colour matching from one batch to another cannot be guaranteed.
12. This product should not be cleaned with a hose.
13. This product has been designed to operate in ambient temperatures 0°C to 40°C.

Warranty

Famco Lighting guarantees this lighting unit for a period of 12 months from date of despatch, solely against failure arising from faulty materials or workmanship, and provided that the unit has been stored, shipped, installed, used and maintained in accordance with the manufacturers instructions and relevant standards. Misuse, negligence or modification of the unit voids all warranties. Consult Famco Lighting Pty Ltd Conditions of Sale for details on warranty liability. If this lighting unit is faulty, return the unit freight pre-paid to your point of purchase, or contact Famco Lighting Pty Ltd on +61 (03) 9935 7300.

Customer Service

For all Customer Service and Technical Support enquires please call Monday to Friday during business hours.

Famco Lighting PTY LTD
+61 (03) 9935 7300
www.famco.com.au

ABN: 22 091 160 440